

JOURNAL OF TRANSPORT



ISSUE 1, 2026 vol. 3

E-ISSN: 2181-2438

ISSN: 3060-5164



RESEARCH, INNOVATION, RESULTS



**TOSHKENT DAVLAT
TRANSPORT UNIVERSITETI**

Tashkent state
transport university



JOURNAL OF TRANSPORT

RESEARCH, INNOVATION, RESULTS

E-ISSN: 2181-2438

ISSN: 3060-5164

VOLUME 3, ISSUE 1

MARCH, 2026



jot.tstu.uz

TASHKENT STATE TRANSPORT UNIVERSITY

JOURNAL OF TRANSPORT

SCIENTIFIC-TECHNICAL AND SCIENTIFIC INNOVATION JOURNAL

VOLUME 3, ISSUE 1 MARCH, 2026

EDITOR-IN-CHIEF

SAID S. SHAUMAROV

Professor, Doctor of Sciences in Technics, Tashkent State Transport University

Deputy Chief Editor

Miraziz M. Talipov

Doctor of Philosophy in Technical Sciences, Tashkent State Transport University

The “**Journal of Transport**” established by Tashkent State Transport University (TSTU), is a prestigious scientific-technical and innovation-focused publication aimed at disseminating cutting-edge research and applied studies in the field of transport and related disciplines. Located at Temiryo‘lchilar Street, 1, office 465, Tashkent, Uzbekistan (100167), the journal operates as a dynamic platform for both national and international academic and professional communities. Submissions and inquiries can be directed to the editorial office via email at jot@tstu.uz.

The Journal of Transport showcases groundbreaking scientific and applied research conducted by transport-oriented universities, higher educational institutions, research centers, and institutes both within the Republic of Uzbekistan and globally. Recognized for its academic rigor, the journal is included in the prestigious list of scientific publications endorsed by the decree of the Presidium of the Higher Attestation Commission No. 353/3 dated April 6, 2024. This inclusion signifies its role as a vital repository for publishing primary scientific findings from doctoral dissertations, including Doctor of Philosophy (PhD) and Doctor of Science (DSc) candidates in the technical and economic sciences.

Published quarterly, the journal provides a broad spectrum of high-quality research articles across diverse areas, including but not limited to:

- Economics of Transport
- Transport Process Organization and Logistics
- Rolling Stock and Train Traction
- Research, Design, and Construction of Railways, Highways, and Airfields, including Technology
- Technosphere Safety
- Power Supply, Electric Rolling Stock, Automation and Telemechanics, Radio Engineering and Communications
- Technological Machinery and Equipment
- Geodesy and Geoinformatics
- Automotive Service
- Air Traffic Control and Aircraft Maintenance
- Traffic Organization
- Railway and Road Operations

The journal benefits from its official recognition under Certificate No. 1150 issued by the Information and Mass Communications Agency, functioning under the Administration of the President of the Republic of Uzbekistan. With its E-ISSN 2181-2438, ISSN 3060-5164 the publication upholds international standards of quality and accessibility.

Articles are published in Uzbek, Russian, and English, ensuring a wide-reaching audience and fostering cross-cultural academic exchange. As a beacon of academic excellence, the "Journal of Transport" continues to serve as a vital conduit for knowledge dissemination, collaboration, and innovation in the transport sector and related fields.

Detection of defects and damages in road bridges and assessment of their load-bearing capacity for the passage of excessive loads

M.Kh. Miralimov¹^a, I.A. Mengliyev¹^b, E.A. Muminov¹^c

¹Tashkent state transport university, Tashkent, Uzbekistan

Abstract: This article investigates the technical condition of the overpass located at the 736+100 km section of the A380 highway and evaluates the possibilities of transporting oversized (out-of-gauge) loads across it. During the research, a comprehensive diagnostic of the structure was conducted, and its load-bearing capacity was analyzed based on the obtained data. Specifically, the transverse distribution coefficients (TDC) of the span structure were determined, and the condition of individual girders was examined in detail. Furthermore, mathematical models were developed using modern computational software to assess the actual operational state of the structure. The impact of identified defects and damages on the structural integrity was substantiated through mathematical methods. Based on the results, specific recommendations were developed regarding the movement patterns of heavy-weight vehicles. Final conclusions are provided for the safe transport of oversized loads, taking into account the residual service life of the overpass.

Keywords: Bridge, oversized load, moving load, support part, damaged supports, vehicle load, protective layer, overpass length, leveling layer, span structure, temporary loads, traffic flow

Avtomobil yo‘l o‘tkazgichining nuqsonlari va shikastlanishlarini aniqlash va nome‘yoriy yukni o‘tkazish uchun uning yuk ko‘tarish qobiliyatini baholash

Miralimov M.X.¹^a, Mengliyev I.A.¹^b, Muminov E.A.¹^c

¹Toshkent davlat transport universiteti, Tashkent, O‘zbekiston

Annotatsiya: Ushbu maqolada A380 avtomobil yo‘lining 736+100 km qismida joylashgan yo‘l o‘tkazgichning texnik holati va undan me‘yordan ortiq (nogabarit) yuklarni o‘tkazish imkoniyatlari tadqiq etilgan. Tadqiqot davomida inshoot to‘liq diagnostikadan o‘tkazilib, olingan natijalar asosida uning yuk ko‘tarish qobiliyati tahlil qilindi. Xususan, oraliq qurilmaning ko‘ndalang o‘rnatish koeffitsiyentlari (KO‘K) aniqlanib, alohida balkalarning holati batafsil o‘rganildi. Shuningdek, konstruksiyaning haqiqiy ishchi holatini baholash maqsadida zamonaviy hisob-kitob dasturlari yordamida matematik modellar yaratildi. Tadqiqot davomida aniqlangan nuqson va shikastlanishlarning inshoot mustahkamligiga ta‘siri matematik usullarda asoslab berildi. Olingan natijalar asosida og‘ir vaznli transport vositalarining harakatlanish sxemasi bo‘yicha maxsus tavsiyalar ishlab chiqildi. Yo‘l o‘tkazgichning qoldiq resursini hisobga olgan holda nogabarit yuklarni xavfsiz o‘tkazish bo‘yicha xulosalar berildi.

Kalit so‘zlar: Ko‘prik, nogabarit yuk, harakatlanuvchi yuk, tayanch qismi, shikastlangan tayanchlar, avtmobil yuki, himoya qatlam, yo‘l o‘tkazgich uzunligi, tekislovchi qatlam, oraliq qurilma, vaqtincha yuklar, transport oqimi

1. Kirish

Dunyoda ko‘priklar har qanday transport tizimining ajralmas qismi bo‘lib, ularning ishonchligi va xavfsizligi butun dunyoda dolzarb masala hisoblanadi. Bugungi kunda ko‘priklarning eskirishi, ortib borayotgan yuklamalar, tabiiy ofatlar va moliyaviy cheklorlar kabi muammolar global darajada ahamiyat kasb etmoqda. Ko‘plab ko‘priklar o‘tgan asrda qurilgan bo‘lib, zamonaviy transport va iqlim sharoitlariga mos emas. Ushbu masalalar ko‘priklarning mustahkamligi va uzoqqa chidamliligini ta‘minlash uchun yangi texnologiyalar, innovatsion materiallar, ilg‘or

loyihalash va hisoblash usullarini joriy etish eng muhim masalalardan hisoblanadi. Hozirgi kunda rivojlangan mamlakatlarda xususan, AQSh, Shveysariya, Janubiy Koreya, Rossiya, Xitoyda ko‘priklar, yo‘llar va boshqa transport inshootlarini loyihalash zamonaviy ilg‘or texnologiyalar hamda loyihalashning texnik vositalaridan foydalanish yo‘li bilan amalga oshirilmoqda.

A. A380 avtomobil yo‘lining 736+100 km qismidagi yo‘l o‘tkazgich

^a <https://orcid.org/0000-0003-2530-5516>

^b <https://orcid.org/0000-0002-3235-1521>

^c <https://orcid.org/0009-0003-1268-0912>



A.1. Inshoot haqida qisqacha ma'lumot

- yo'l o'tkazgich uzunligi -66,60 m.
- yo'l o'tkazgich (eski) o'qi bo'ylab bo'ylama sxema - 18x24x18 m.
- yo'l o'tkazgich (yangi kengaytirilgan) o'qi bo'ylab bo'ylama sxema - 18x24x24 m.
- eni bo'yicha gabarit - G - 12,0+0,6+11,5+ 2*0,75 (trotuarlar bilan).
- eski yo'l o'tkazgich foydalanishga topshirilgan yil 1988 y.
- eski yo'l o'tkazgich foydalanishga topshirilgan yil 2013 y.
- to'siq – temir yo'l.
- loyihaviy yuklamalar - N-30, NK-80, A11 va NK-80.
- avtomobil yo'li toifasi - I.
- avtoyo'ldagi qatnov qismi soni - 4.
- oraliq qurilma turi - to'sinli (kesilgan).
- oraliq qurilmaning ko'ndalang kesimidagi to'sinlar soni - eski yo'l o'tkazgichning 1- va 3- oraliqlari 8 tadan iborat.

TP 3.503-14, inv.710/5 seriyali, uzunligi 18,0 m bo'lgan, zo'riqtirilmagan armaturali, tavr kesimli to'sinlar. To'sinlar o'zaro temir-beton monolitlash choklari yordamida qatnov qismi plitalari sathida 15 sm qalinlikda birlashtirilgan. To'sinlarning hisobiy oraliq'i 17,40 m, to'sinlarning balandligi 105 sm. To'sin qirralari orasidagi masofa 170 sm oraliq'ida. Oraliq qurilma materiali - B25 sinfidagi temir-beton.

O'rta oraliq qurilma TP 3.503.1-81 bo'yicha 24 m uzunlikdagi 6 dona oldindan zo'riqtirilgan to'sinlardan iborat. To'sinlar o'zaro temir-beton monolit choklar yordamida yo'l qatnov qismi plitalari sathida 15 sm qalinlikda birlashtirilgan. To'sinlarning hisobiy oraliq'i 23,40 m, to'sinlarning balandligi 120 sm. To'sin qirralari orasidagi masofa 240 sm oraliq'ida. Oraliq qurilma materiali - B35 sinfidagi temir-beton.

Yo'l o'tkazgichning kengaytirilgan qismining oraliq qurilmasi quyidagilardan iborat: 1-oraliqda TP 3.503-14 seriyasi, inv.710/5 bo'yicha uzunligi 18 m bo'lgan 7 dona tavrli to'sinlardan. To'sinlar o'zaro temir-beton monolitlash choklari yordamida qatnov qismi plitalari sathida 15 sm qalinlikda birlashtirilgan. To'sinlarning hisobiy oraliq'i 17,40 m, to'sinlarning balandligi 105 sm. To'sin qirralari orasidagi masofa 165-170 sm oraliq'ida. Oraliq qurilma materiali - B25 sinfidagi temir-beton. O'rta va chetki oraliq qurilmalar oldindan zo'riqtirilgan 5 dona 24 m uzunlikdagi to'sinlardan iborat, TP 3.503-12 bo'yicha, inv. 384/31. To'sinlar o'zaro temir-beton monolit choklar yordamida yo'l qatnov qismi plitalari sathida 15 sm qalinlikda birlashtirilgan. To'sinlarning hisobiy oraliq'i 23,40 m, to'sinlarning balandligi 120 sm. To'sin qirralari orasidagi masofa 240 sm oraliq'ida. Oraliq qurilma materiali - B35 sinfidagi temir-beton.

- ko'prik to'shasining turi - asfaltbeton.
- yo'l poyi qatlamlarining o'rtacha qalinligi -16-20 sm.
- panjara -temir-beton.
- yig'ma temir-betondan tayyorlangan hoshiya to'siq.
- yo'l o'tkazgichning oraliq va qirg'oq tayanchlari (ustunlari) temir-betondan 40x50 sm kesimli ustunsimon qilib poydevorga qo'yiladi.

Yo'l o'tkazgichning ko'ndalang kesimida 6 dona o'rnatilgan bo'lib, ular monolit rigel va nasadka bilan birlashtirilgan. Yo'l o'tkazgichning kengaytirilgan qismining ustunlari kesimi 35x35 sm bo'lgan prizmatik ikki qatorli qoziqlardan iborat bo'lib, ustki tomondan qoziqlar

monolit nasadka bilan birlashtirilgan. Yo'l o'tkazgichning kengaytirilgan qismining oraliq tayanchlari 3 dona metall quvurlardan ustunsimon qilib tayyorlangan. Ustunlar yuqoridan yaxlit temir-beton rigel bilan birlashtirilgan.

- tayanch qismlari - rezinali.

Elementlarning quyidagi raqamlanishi va belgilanishi qabul qilingan:

tayanchlarning №1 dan boshlab kilometrning ortib borishi bo'yicha raqamlanishi;

oraliq qurilma to'sinlarining raqamlanishi - kilometrning o'sish yo'nalishi bo'yicha chapdan o'ngga;

ko'ndalang yo'nalishda tomonlarning belgilanishi - kilometrlarning o'sishiga nisbatan chap va o'ng.

Zamonaviy loyihalash me'yorlari SHNQ 2.05.03-22 ga muvofiq quyidagi talablarni belgilaydi:

- umumiy foydalanishdagi avtomobil yo'llarida harakatlanuvchi tarkibdan tushadigan me'yoriy vaqtinchalik tik yuklamalar - A14, NK-100.

Yo'l o'tkazgichning umumiy ko'rinishi A.1-rasmda keltirilgan.

2. Tadqiqot metodologiyasi

Yo'l o'tkazgichning nuqsonlari va shikastlanishlari Ko'prik polotnosi

Qatnov qismining yuzasida chetki oraliqlarning deformatsiya choklari qismida yoriqlar, asfaltbeton qoplamada chuqurchalar mavjud. Qatnov qismining xavfsizlik bo'lagida trotuar va g'ildirak qaytargichning tutashgan joyida o'rta oraliqda asfalt-beton qoplamada yoriq mavjud. Trotuar plitasi va g'ildirak qaytaruvchi brusning vertikalidan qiyshayishi mavjud (2-rasm). Buning sababi trotuar plitasining haddan tashqari bo'rtib chiqishi va bu qismdagi elementlarning bir-biriga mustahkam ulanmaganligidir.



1-Rasm. Yo'l o'tkazgichning umumiy ko'rinishi



2-Rasm. Yo'l o'tkazgichning asfalt-beton qoplamasidagi yoriqlar

Oraliq qurilmalar

Yo'l o'tkazgichning eski qismida, chetki oraliq qurilmalarning deyarli barcha to'sinlarida qovurg'alarda (boshida va oxirida) beton yoriqlari mavjud, ba'zi to'sinlarda ishchi armaturaning ochilishi ham shu yerda sodir bo'lgan. choklarini betonlashda, ayniqsa suv chiqarish quvurlari va deformatsion choklar joylarida beton korroziyasi va himoya qatlamlarining tushib ketishi kuzatiladi (3-Rasm.). O'rta oraliq qurilmali to'sinlar yaxshi saqlangan, biroq suv chiqarish quvurlari va deformatsion choklarning ba'zi joylarida beton korroziyasi va himoya qatlamlarining tushishi mavjud.



3-Rasm. Oraliq qurilmalardagi nuqsonlar

Tayanchlar

Eski va kengaytirilgan yo'l o'tkazgichning oraliq tayanchlari, jumladan rigel va nasadkalarining holati yaxshi holatda (4-Rasm). Tayanch va qoziqlarning nasadkalarida ishqorlanish, betonning sinishi va yoriqlar mavjud. Shkaf devorida ham yoriqlar bor. Tayanch konstruksiyalarida deformatsiyalar aniqlanmadi. Biroq, tayanch konuslarida gruntlarda ba'zi cho'kishlar aniqlandi (5-Rasm).



4-Rasm. Oraliq tayanchlarning holatlari



5-Rasm. Tutash uchastkalardagi qiyaliklar va konuslar ba'zi joylarda deformatsiyalangan

Yuk ko'tarish qobiliyatiga hisoblash

Yo'l o'tkazgichning 1-oraliq'idan o'tkazish uchun o'qqa tushadigan ruxsat etilgan yuklamani aniqlash

Oraliq qurilmalarning holatidan kelib chiqib, me'yordan ortiq yuklamani o'tkazish uchun yo'l o'tkazgichning kengaytirilgan yangi qismini tanlaymiz, u avtomobillar harakati Buxoro shahridan Nukus shahriga yo'naltirilgan. Ushbu qismning birinchi oraliq'i, avval ta'kidlanganidek, 7 ta balkadan iborat (6-rasm). To'sinlarning holati qoniqarli



6-Rasm. Yo'l o'tkazgichning kengaytirilgan qismi 1-oraliq qurilmasining ko'ndalang kesimi

Yo'l uchun oraliq qurilmaga tushadigan vaqtinchalik yuklama avtotransport vositalaridan olinadi, ya'ni vaqtinchalik yuklama sifatida 8-rasmda ko'rsatilganidek, gabaritsiz transport vositalaridan tushadigan me'yordan ortiqcha yuklama olinadi. Oraliq qurilmaning bitta balkasi uchun 1 m uzunlikdagi doimiy yuk qabul qilinayotgan qatlamlarning xususiy og'irliklaridan 1-jadvalga muvofiq qabul qilinadi. [14] ga ko'ra, normal kesimdagi chegaraviy eguvchi moment uzunligi 18 m bo'lgan tavr balka uchun $M_{cheg}=195,5$ tm ni tashkil etadi. Oraliq qurilmaga tushadigan doimiy yuk hisobiy uzunligi $L_p=17,4$ m bo'lgan karkas to'sinlar va yo'l to'shamasining xususiy og'irligidan iborat. Balkaning 1 m uzunligiga tushadigan o'zgarma yuk quyidagi jadvalda keltirilgan. 1. (7-rasm).

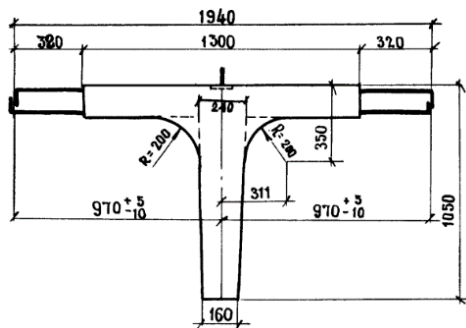

7-Rasm. Uzunligi 18 m bo'lgan to'sin kesimi

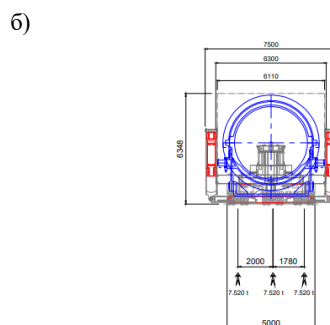
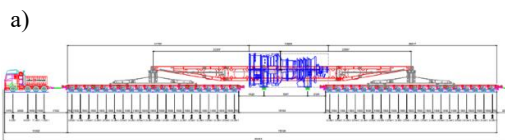

8-Rasm. Me'yordan ortiq yuklamani joylashtirishning umumiy sxemasi:

a) bo'ylama qirqim, b) ko'ndalang qirqim

902,400 t ga teng bo'lgan umumiy yuk bo'ylama yo'nalishda har biri 1,5 m masofada 40 dona o'q chiziq'lari orqali taqsimlangan. Bunda har bir o'q 22,560 t yukni ko'taradi. Ko'ndalang kesimda yuk 7,520 t ga teng bo'lgan uchta to'plangan kuch ko'rinishida bo'lingan (9-rasm).

Oraliq qurilma plitalari orasida vaqtinchalik yuklamani taqsimlash. Elastik tayanchlar usuli. Bu usulda oraliq qurilma balkalaridagi bosimning ta'sir chizig'i yuklanish o'qlari ostidagi ordinatalar qiymatlari bo'yicha quriladi. Buning uchun ishlab chiqilgan dastur bo'yicha KO'K (ko'ndalang o'rnatish koeffitsiyenti) ni aniqlash masalasi yechiladi. 10-Rasmda markazdagi har bir balkaga bosimning ta'sir chizig'i ordinatalarining epyuralari keltirilgan.

Ko'ndalang o'rnatish koeffitsiyentlarini yuk uchun alohida transport birliklarining og'irlik markazlari ostidagi bosim ta'sir chizig'i ordinatalarining yig'indisi sifatida aniqlaymiz. Yuklama ta'sir chizig'ini yuklashda o'tish yo'lining o'lchamlari va o'qlarni joylashtirish qoidalarini hisobga olgan holda eng xavfsiz holatga o'rnatamiz. Oraliq qurilmada qabul qilingan gabarit bitta harakat polosasini ko'zda tutadi, bunda treylarning markaziy g'ildiragi qatnov qismining o'rtasiga o'rnatiladi, bu yerda o'rta g'ildirak 4-balkaga to'g'ri keladi (9-rasm).

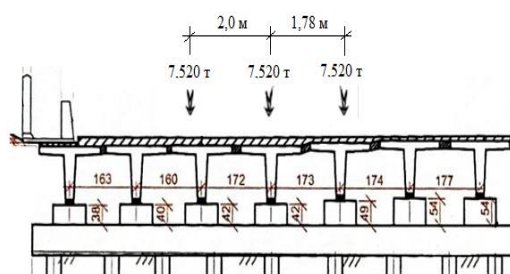

9-Rasm. Oraliq qurilmani yuklash



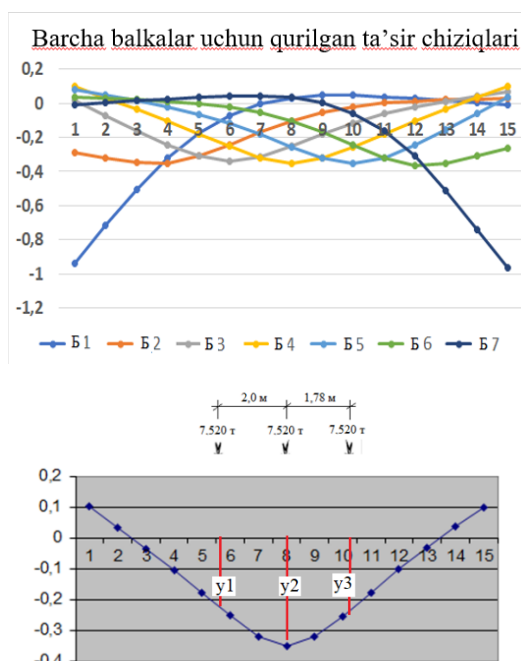

10-Rasm. Barcha balkalar va 4-maksimal yuklangan balka uchun qurilgan birlik yukdan bosimning ta'sir chiziqlari

Olingan qiymatlar 4-balka eng ko'p yuklanganligini ko'rsatdi va bu balka uchun ko'ndalang o'rnatish koeffitsiyenti (KO'K) qiymatini hisoblaymiz.

1-jadval

Yuklamaning nomi va uni hisoblash	Me'yori y qiymat t/m	Ishonchlilik koeffitsiyenti γ_f	Hisoblangan qiymat t/m
Qalinligi 10 sm bo'lgan qatnov qismi asfalt-betoni (tekshiruv natijalariga ko'ra), ($\gamma = 2.3 \text{ t/m}^3$)	0,378	1.5	0,567
Qalinlikdagi himoya qatlami 4 cm ($\gamma = 2.5 \text{ t/m}^3$)	0,164	1.3	0,214
Qalinlikdagi gidrozolyatsiya 1 cm ($\gamma = 1.5 \text{ t/m}^3$)	0,025	1.3	0,032
3 sm qalinlikdagi tekislovchi qatlam ($\gamma = 2.5 \text{ t/m}^3$)	0,104	1.3	0,135
Balandligi 105 sm bo'lgan temir-beton karkasli to'sin ($\gamma = 2.5 \text{ t/m}^3$) c ionlash choklarining og'irligini hisobga olgan holda	1,11	1.1	1,221
JAMI	1,780		2,168

Bunda bitta polosadan tushadigan yuk oraliq qurilma gabaritining o'rtasida o'rnatilgan uchta o'qli aravacha uchun bo'lgani kabi bo'ladi:

$$KIIY_{AT} = (y_1 + y_2 + y_3)/3 = (0,21 + 0,35 + 0,24)/3 = 0,2667$$

Balkalardagi ichki zo'riqishlarni aniqlash. Chegaraviy holatdagi balkaning yuk ko'tarish qobiliyatini aniqlash. Ko'rsatilganidek, to'sinlar uchun namunaviy loyihada keltirilgan ma'lumotlarga ko'ra chegaraviy moment quyidagiga teng: $M_{cheg} = 195,5 \text{ TM}$

Balkaga tushadigan o'zgarmas yukdan hisobiy eguvchi momentni aniqlash. Oraliqning o'rtasidagi hisobiy eguvchi moment quyidagiga teng bo'ladi:

$$M_q = \frac{1}{8} q_{doim} \times l^2 = \frac{1}{8} 2,168 \times 17,4^2 = 82,046 \text{ TM}$$

Hisobiy eguvchi momentni balkaga qo'yilgan me'yordan ortiq yukdan aniqlash. Buning uchun o'qqa tushadigan yukni KO'K qiymatiga ko'paytiramiz, so'ngra balka uchun taqsimlangan yukni olamiz.

$$q_{vaq}^{his} = \frac{22,56}{1,5} KIIY = \frac{22,56}{1,5} 0,2667 = 4,011 \text{ t/m}$$

$$M_{vaq}^{his} = \frac{1}{8} q_{vaq}^{his} \times l^2 = \frac{1}{8} 4,011 \times 17,4^2 = 151,803 \text{ TM}$$

Yo'l o'tkazgichning yuk ko'tarish qobiliyatini me'yordan ortiq yukni o'tkazish bo'yicha aniqlash. Yuklash uzunligida aravacha (trejler) uchun yuk bo'yicha ishonchlik koeffitsiyenti quyidagiga teng bo'ladi:

$$\gamma_{fAT} = 1,0$$

Yuk kichik tezlikda harakatlangani uchun yuk uchun dinamik koeffitsiyent quyidagiga teng bo'ladi:

$$(1 + \mu) = 1,0$$

Balka o'rtasidagi momentni hisobga olishda

$M_{bpeM}^{pacH} = 151,803 \text{ TM}$, o'qqa tushadigan ruxsat etilgan yukni quyidagilarni hisobga olgan holda topamiz:

$$P = \left(\frac{M_{cheg}^{erm} - M_q}{M_{vaq}^{hisob}} \right) P_{TP} = \frac{195,5 - 82,046}{151,803} 22,56 = 16,861 \text{ T}$$

Yuk o'tmaydi, chunki $R = 16,861 \text{ t} < 22,56 \text{ t}$ - balkalarning yuk ko'tarish qobiliyati pasaytirilgan (oraliq qurilma). Asfaltni olib tashlaymiz. U holda quyidagilarni hisobga olgan holda o'qqa tushadigan ruxsat etilgan yukni topamiz:

$$M_q = \frac{1}{8} q_{doim} \times l^2 = \frac{1}{8} 1,601 \times 17,4^2 = 60,596 \text{ TM}$$

$$P = \left(\frac{M_{cheg}^{arm} - M_q}{M_{vaq}^{hisob}} \right) P_{TP} = \frac{195,5 - 60,596}{151,803} 22,56 = 20,049 \text{ T}$$

Bu holda ham yuk o'tmaydi, chunki $P = 20,049 \text{ t} < 22,56 \text{ t}$ - balkalarning yuk ko'tarish qobiliyati pasaytirilgan (oraliq qurilma). Shu munosabat bilan oraliq qurilmani tekislovchi va himoya qatlamlari o'rniga qalinligi 7 sm bo'lgan B35 sinfli betondan tayyorlangan qatlamli temirbeton plita va diametri 12 mm bo'lgan A400 bo'ylama armatura bilan



kuchaytirish talab etiladi. Monolit plitaning deformatsiyasini hisobga olgan holda KO'K ni qayta hisoblaymiz (6-rasm).

Olingan qiymatlar 4- balkaning eng ko'p yuklanganligini ko'rsatdi va bu balka uchun ko'ndalang o'rnatish koeffitsiyentining (KO'K) yangi qiymati hisoblandi.

$$KO'K_{AT} = (y_1 + y_2 + y_3)/3 = (0,2 + 0,27 + 0,21)/3 = 0,227$$

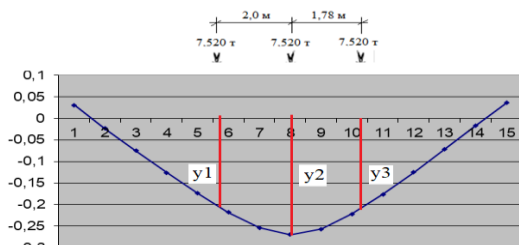

11-Rasm. Monolit plitaning deformatsiyasini hisobga olgan holda 4-maksimal yuklangan to'sin uchun qurilgan birlik yukdan bosimning ta'sir chiziqlari

Yangi KPUni hisobga olgan holda balkaga tushadigan me'yordan ortiq yukdan hosil bo'ladigan hisobiy eguvchi momentni aniqlash. Buning uchun o'qqa tushadigan yukni KO'K qiymatiga ko'paytiramiz, so'ngra balka uchun taqsimlangan yukni olamiz.

$$q_{vaq}^{hisob} = \frac{22,56}{1,5} KO'K = \frac{22,56}{1,5} \cdot 0,227 = 3,414 \text{ t/m}$$

$$M_{vaq}^{hisob} = \frac{1}{8} q_{vaq}^{hisob} \times l^2 = \frac{1}{8} \cdot 3,414 \times 17,4^2 = 129,206 \text{ tM}$$

Yo'l o'tkazgichning yuk ko'tarish qobiliyatini me'yordan ortiq yukni o'tkazish bo'yicha aniqlash. Yuklash uzunligida aravacha (trejler) uchun yuk bo'yicha ishonchlik koeffitsiyenti quyidagiga teng bo'ladi:

$$\gamma_{\text{AT}} = 1,0$$

Yuk kichik tezlikda harakatlangani uchun yuk uchun dinamik koeffitsiyent quyidagiga teng bo'ladi:

$$(1 + \mu) = 1,0$$

Balkaning o'rtasidagi momentni hisobga olgan $M_{bvaq}^{hisob} = 129,206 \text{ tM}$, o'qqa tushadigan ruxsat etilgan yukni quyidagilarni hisobga olgan holda topamiz:

$$P = \left(\frac{M_{cheg}^{apm} - M_q}{M_{vaq}^{hisob}} \right) P_{TP} = \frac{195,5 - 60,596}{129,206} \cdot 22,56 = 23,555 \text{ t}$$

Bu holda yuklama o'tadi, chunki $P = 23,555 \text{ t} > 22,56 \text{ t}$ - yo'l o'tkazgichning (oraliq qurilmasining) yuk ko'tarish qobiliyati ta'minlanadi.

Yo'l o'tkazgichning 2- va 3-oraliq'idan o'tkazish uchun o'qqa tushadigan ruxsat etilgan yuklamani aniqlash

Yo'l uchun oraliq qurilmaga tushadigan vaqtinchalik yuklama avtotransport vositalaridan olinadi, ya'ni vaqtinchalik yuklama sifatida 8-rasmda ko'rsatilganidek,

gabaritsiz transport vositalaridan tushadigan me'yordan ortiqcha yuklama olinadi.

Oraliq qurilmaning 1 m uzunligiga va undan bitta to'sin uchun doimiy yuk qabul qilinayotgan qatlamlarning xususiy og'irliklaridan 2-jadvalga muvofiq qabul qilinadi. [15] ga muvofiq, normal kesimdagi chegaraviy eguvchi moment uzunligi 24 m bo'lgan tavr balka uchun $M_{cheg} = 430,6 \text{ tM}$ ni tashkil etadi.

Hisoblashlarda oraliq qurilmaga tushadigan doimiy yuk hisobiy uzunligi $L_p = 23,4 \text{ m}$ bo'lgan oldindan zo'riqtirilgan to'sinlar va yo'l to'shmasining xususiy og'irlikidan iborat bo'ladi. Balkadagi ostki armatura: 9 bog'lama 24Ø5 V-P.

902,400 t ga teng bo'lgan umumiy yuk bo'yilama yo'nalishda har biri 1,5 m masofada 40 dona o'q chiziqlari orqali taqsimlangan. Bunda har bir o'q 22,560 t yukni ko'taradi. Ko'ndalang kesimda yuk 7,520 t ga teng bo'lgan uchta to'plangan kuch ko'rinishida bo'lingan.

Oraliq qurilmalar zo'riqtirilgan armaturalari, uzunligi 24 m bo'lgan 5 ta tavr kesimli to'sinlardan tashkil topgan (12-rasm). To'sinlarning hisobiy oraliq'i 23,40 m, to'sinlarning balandligi 120 sm. To'sinlarning qirralari orasidagi masofa 240 sm oraliq'ida. Oraliq qurilmaning materiali - B35 sinfidagi temir-beton.

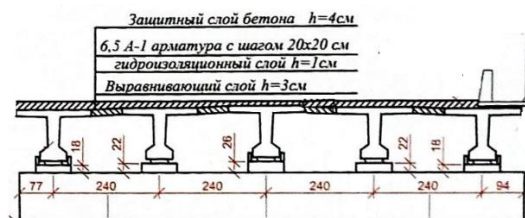

12-rasm. Yo'l o'tkazgichning kengaytirilgan qismining 2- va 3-oraliq qurilmasining ko'ndalang kesimi

Oraliq qurilma plitalari orasida vaqtinchalik yuklamani taqsimlash. Elastik tayanchlar usuli.

Bu usulda oraliq qurilma balkalaridagi bosimning ta'sir chizig'i yuklanish o'qlari ostidagi ordinatalar qiymatlari bo'yicha quriladi. Buning uchun ishlab chiqilgan dastur bo'yicha har bir balka uchun KO'K (ko'ndalang o'rnatish koeffitsiyenti) ni aniqlash masalasi yechiladi. 9-rasmda oraliq qurilmani transport yuki bilan yuklash sxemasi, uning joylashuvi va har bir "1- 5" balkaga bosimning ta'sir chizig'i ordinatalarining olingan epyuralari keltirilgan.

Ko'ndalang o'rnatish koeffitsiyentlarini (KO'K) yuk uchun alohida transport birliklarining og'irlik markazlari ostidagi bosimning ta'sir chizig'i ordinatalari yig'indisi sifatida aniqlaymiz. Yuklamaning ta'sir chizig'ini yuklashda o'tish yo'lining o'lchamlari va o'qlarni joylashtirish qoidalarini hisobga olgan holda eng xavfsiz holatga o'rnatamiz (8-rasm).

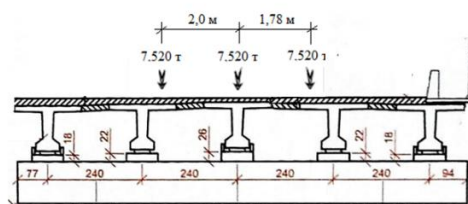

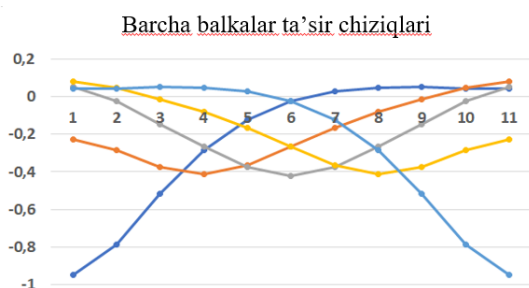

13-Rasm. Oraliq qurilmaning yuklanishi va elastik tayanchlar usuli bilan olingan oraliq qurilmaning uzunlik birligiga bosimning ta'sir chizig'i

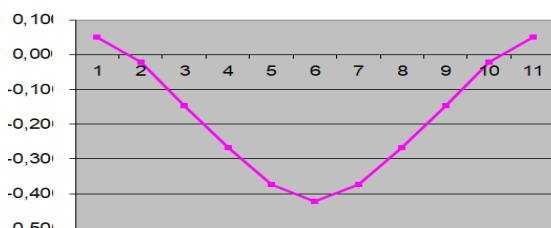

14-rasm. Eng ko'p yuklangan 3-to'sin uchun ta'sir chizig'i

2-jadval

24 m kenglikni hisobga olgan holda bitta balka uchun uning 1 m diametriga tushadigan doimiy yuk

Yukning nomi va uni hisoblash.	Me'yoriy qiymat. t/m	Ishonchlilik koeffitsiyenti. γ_f	Hisobiy qiymat. t/m
Qatnov qismidagi 7 sm qalinlikdagi asfaltbeton (tekshiruv natijalariga ko'ra), ($\gamma = 2,3 \text{ t/m}^3$)	0,483	1,5	0,725
4 sm qalinlikdagi himoya qatlami. ($\gamma = 2,5 \text{ t/m}^3$)	0,240	1,3	0,312
1 sm qalinlikdagi gidroizolyatsiya. ($\gamma = 1,5 \text{ t/m}^3$)	0,032	1,3	0,047
3 sm qalinlikdagi tekislovchi qatlam. ($\gamma = 2,1 \text{ t/m}^3$)	0,151	1,3	0,197
Asosiy balkaning o'z vazni, monolitlash tikuvini hisobga olgan holda.	1,729	1,1	1,902

($\gamma = 2,5 \text{ t/m}^3$)			
JAMI	2,639		3,182

Oraliq qurilmada qabul qilingan gabarit bitta harakat polosasini ko'zda tutadi, bunda treylerning markaziy g'ildiragi qatnov qismining o'rtasiga o'rnatiladi, bu yerda o'rta g'ildirak 3-balkaga to'g'ri keladi (14-rasm).

Bir yuk tasmasidan ko'ndalang o'rnatish koeffitsiyenti maksimal yuklanadigan to'sin uchun oraliq qurilma gabaritining o'rtasida o'rnatilgan uch o'qli aravacha kabi bo'ladi:

$$KO \cdot K_{Ar} = (y_1 + y_2 + y_3)/3 = (0,32 + 0,4 + 0,3)/3 = 0,34$$

Balkalardagi ichki zo'riqishlarni aniqlash. Chegaraviy holatdagi balkaning yuk ko'tarish qobiliyatini aniqlash. Ko'rsatilganidek, namunaviy loyihada (TP 3.503-12, inv.384/31) keltirilgan ma'lumotlarga ko'ra, 24 m uzunlikdagi to'sinlar uchun chegaraviy moment quyidagiga teng:

$$M_{cheg} = 430,6 \text{ TM.}$$

Balkaga tushadigan o'zgarmas yukdan hisobiy eguvchi momentni aniqlash. Yengillashtirish uchun oraliq qurilmadan asfaltni olib tashlaymiz. U holda oraliqning o'rtasidagi hisobiy eguvchi moment quyidagiga teng bo'ladi:

$$M_q = \frac{1}{8} q_{doim} \times l^2 = \frac{1}{8} 2,457 \times 23,4^2 = 168,2 \text{ TM}$$

Hisobiy eguvchi momentni balkaga qo'yilgan me'yordan ortiq yukdan aniqlash. To'sin uchun momentlar epyurasining olingan qiymatlari 11-rasmda keltirilgan.

Yo'l o'tkazgichning yuk ko'tarish qobiliyatini me'yordan ortiq yukni o'tkazish bo'yicha aniqlash. Yuklash uzunligida aravacha (treylar) uchun yuk bo'yicha ishonchlilik koeffitsiyenti quyidagiga teng bo'ladi:

$$\gamma_{fAr} = 1,0$$

Yuk kichik tezlikda harakatlangani uchun yuk uchun dinamik koeffitsiyent quyidagiga teng bo'ladi:

$$(1 + \mu) = 1,0$$

При учете момента в середине балки $M_{vaq}^{hisob} = 350,0 \text{ TM}$, находим допустимую нагрузку на ось с учетом для путепровода:

Balkaning o'rtasidagi momentni hisobga olgan holda $M_{vaq}^{hisob} = 350,0 \text{ tm}$, yo'l o'tkazgich uchun quyidagilarni hisobga olgan holda o'qqa tushadigan ruxsat etilgan yukni topamiz:

$$P = \left(\frac{M_{cheg}^{apm} - M_q}{M_{doim}^{hisob}} \right) P_{HK} = \frac{430,6 - 168,2}{350,0} 22,56 = 16,914 \text{ T}$$



3. Xulosa

Yuk o'tmaydi, chunki $P_{NK}=22,560$ t ruxsat etilgan $P=16,914$ t dan katta: $P=16,914$ t < $P_{NK}=22,560$ t. Shu munosabat bilan oraliq qurilmani tekislovchi va himoya qatlamlari o'rniga qalinligi 7 sm bo'lgan B35 sinfli betondan tayyorlangan qatlamli temir-beton plita va diametri 12 mm bo'lgan A400 bo'ylama armatura bilan kuchaytirish talab etiladi.

1-oraliq uchun me'yorida ortiq yukni o'tkazish bo'yicha xulosa qilingan ishlar ro'yxati

1-oraliqdan me'yorida ortiq yukni o'tkazish uchun quyidagi ish turlarini bajarish nazarda tutiladi:

1. Oraliq qismidan asfalt qoplamasini olib tashlash;
2. Oraliqda tekislovchi va himoya qatlamini olib tashlash;
3. Qalinligi 7 sm bo'lgan monolit temirbeton plitani o'rnatish;
4. Monolit temirbeton plita o'rnatilgandan so'ng, lekin asfalt yotqizilmasdan turib, yukni (treylerni) yo'l o'tkazgichdan o'tkazish;
5. Yuk (treylar) o'tkazilgandan keyin oraliq qurilmasiga asfalt qoplamasini yotqizish mumkin.

2- va 3-oraliqlar uchun me'yordan ortiq yuklamani o'tkazib yuborish bo'yicha xulosa qilingan ishlar ro'yxati

1-oraliq uchun me'yordan ortiq yukni o'tkazish uchun quyidagi ish turlarini bajarish ko'zda tutilgan:

1. Oraliqdan asfalt olib tashlash;
2. Oraliqdagi tekislovchi va himoya qatlamini olib tashlash;
3. Qalinligi 7 sm bo'lgan monolit temir-beton plitani o'rnatish;
4. Yo'l o'tkazgich bo'yab yuklama (treylar) monolit temir-beton plita o'rnatilgandan so'ng, lekin asfalt o'rnatmasdan amalga oshiriladi;
5. Yuk (treylar) o'tkazilgandan so'ng oraliq qurilmaga asfalt yotqizish mumkin.

Foydalangan adabiyotlar / References

- [1] ШНК 2.05.03-22. Мосты и трубы.
- [2] ШНК 3.06.07-08. Мосты и трубы. Правила обследования и испытаний.
- [3] КМК 2.03.11-96. Защита строительных конструкций от коррозии.
- [4] КМК 3.01.02-00. Техника безопасности в строительстве.
- [5] МШН 32-04. Инструкция по определению грузоподъемности железобетонных балочных пролетных строений эксплуатируемых автодорожных мостов.
- [6] МШН 4-2004 «Инструкция по проведению осмотров мостовых сооружений и труб на автомобильных дорогах».

[7] ИКН 100-14 «Инструкция по содержанию и текущему ремонту мостовых сооружений и водопропускных труб на автомобильных дорогах».

[8] Гайдук К.В. и др. «Содержание и ремонт мостов и труб на автомобильных дорогах». Российское акционерное общество «Росавтодор». Москва, 1994.

[9] «Методическое пособие мастеров по эксплуатации автодорожных мостов». Российское акционерное общество «Росавтодор». Москва 1994 г.

[10] Руководство по определению грузоподъемности железобетонных пролетных строений железнодорожных мостов. М., Транспорт, 1989.

[11] Содержание и реконструкция мостов/В.О.Осипов, Ю.Г.Козьмин, В.С.Анциперовский, А.А.Кирста/Под ред. В.О.Осипова: Учебник для вузов - М.: Транспорт, 1986.

[12] Гишман М.Е. Проектирование транспортных сооружений. М.: Транспорт, 1986.

[13] Дементьев В.А., Волокитин В.П., Анисимова Н.А. Усиление и реконструкция мостов на автомобильных дорогах. Воронеж, 2006.

[14] Internet saytlari <http://am-bridge.com/>.

Mualliflar to'g'risida ma'lumot/ Information about the authors

Miralimov Toshkent davlat transport universiteti "Avtomobil yo'llaridagi inshootlar muhandisligi" kafedrasida v.v.b.professor
Mirzoxid
Xamitovich /
Mirzokhid
Miralimov t.f.d., (DSc),
E-mail:
mirzakhid_miralimov@yahoo.com
Tel.:+998977250924
<https://orcid.org/0000-0003-2530-5516>

Mengliyev Toshkent davlat transport universiteti "Amaliy mexanika" kafedrasida v.b.dotsenti, t.f.d.,
Ismoil
Abdunazar o'g'li /
Abdunazar
Mengliyev
E-mail:
ismoilmengliyev399313@gmail.com
Tel.:+998911323993
<https://orcid.org/0000-0002-3235-1521>

Muminov Toshkent davlat transport universiteti "Ko'priklar va tonnellar" kafedrasida doktoranti.
Eldorjon
Anvarovich /
Eldorjon
Muminov
E-mail:
eldorjon.muminov@gmail.com
Tel.:+998932995009
<https://orcid.org/0009-0003-1268-0912>



U. Berdiev, U. Suloymonov, F. Hasanov <i>Magnetocaloric materials based on manganese pnictides</i>	147
Z. Adilova, S. Asenova <i>Developing a hybrid framework for intermodal planning: an integrated statistical and operational model applied to Uzbekistan</i>	150
F. Hasanov <i>Energy efficiency of electric motors based on magnetically soft materials</i>	156
M. Miralimov, I. Mengliev, E. Muminov <i>Detection of defects and damages in road bridges and assessment of their load-bearing capacity for the passage of excessive loads</i>	161